

LR - Straightener with Fixed Roll Sets

Quick release with minimal adjustment for simple applications.

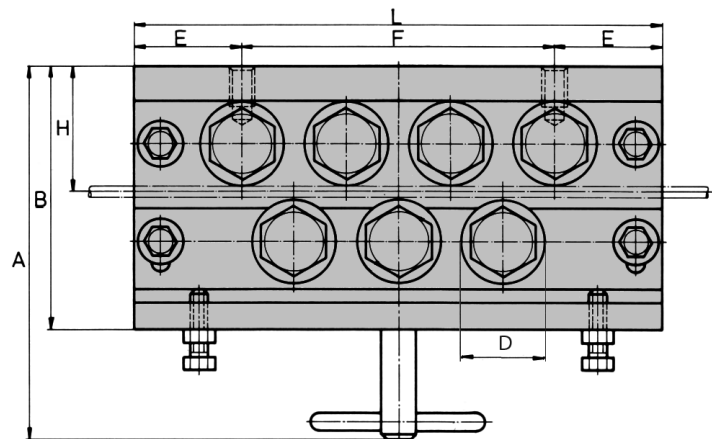

LR7 - Seven Roll Unit

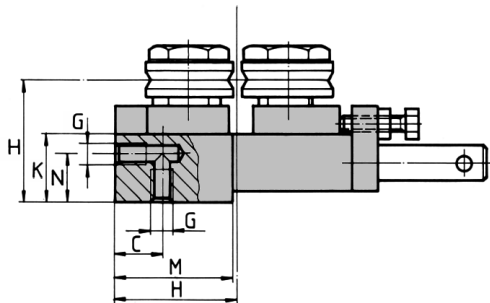
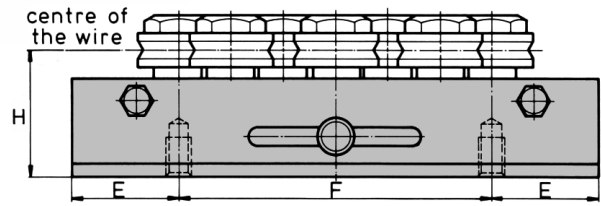

LR Series	Wire Diameter Ranges (mm) ϕ						
	≤ 0.5	0.5 - 0.8	0.8 - 1.5	1.5 - 3.0	3.0 - 4.5	4.5 - 9.0	9.0 - 15.0
7 Roll	LR7-1.5	LR7-1.5	LR7-1.5	LR7-3	LR7-4.5	LR7-9	LR7-15
A	150	150	150	150	150	225	285
B	95	95	95	95	95	142	185
C	22	22	22	22	22	30	45
D	13	17	23	31	35	52	80
E	40	40	40	40	40	60	80
F	114	114	114	114	114	226	290
G	M10	M10	M10	M10	M10	M12	M16
H	48	48	48	48	48	68	91.5
K	25	25	25	25	25	40	50
L	194	194	194	194	194	346	450
M	45	45	45	45	45	70	90
N	12.5	12.5	12.5	12.5	12.5	30	35
Rolls	WR13	WR17	WR23	WR31	WR35	WR52	WR80
Kg	4.8	4.8	4.8	5.1	5.3	19	46.5

	≤ 0.5	0.5 - 0.8	0.8 - 1.5	1.5 - 3.0	3.0 - 5.0
13 Roll	LR13-1.5	LR13-1.5	LR13-1.5	LR13-3	LR13-5
A	135	135	135	145	172
B	85	85	85	95	122
C	22	22	22	22	22
D	13	17	23	31 / 32	40
E	42.5	42.5	42.5	79	74
F	125	125	125	150	240
G	M8	M8	M8	M10	M10
H	42	42	42	48	56
K	27.5	27.5	27.5	25	25
L	210	210	210	308	388
M	40	40	40	45	55
N	22	22	22	12.5	22
Rolls	WR13	WR17	WR23	WR31 / 32	WR40
Kg	4.8	4.8	4.8	8.5	16.3